



Size Range 213 x 239 x 209,5 mm 8,38 x 9,41 x 8,24 " AC HIGH PERFORMANCES CENTRIFUGAL FAN

TECHNICAL DATA

Characteristics

- Weight: 6,5 Kg / 14,37 Lb
- Housing in Aluminium
- Turbine in metal
- L-10 life expectancy at 40°C: 25.000 hours
- Operating temperature range: -10 / +70 °C
- Storage temperature: -54 / +85°C
- Connection: Leads
- GAM T1 listed
- IP40

Options

- Speed sensor
- Other IP levels
- Salt spray protection
- Shocks and vibrations protection
- Marine application
- Wide temperature range
- Other voltages
- Safety switch

ELECTRICAL AND AERAILIC DATA

Part Number	Voltage	Frequency	Nb Phases	Airflow		Pressure		Nominal speed RPM	Noise level LP dBA	Nominal current A	Starting current A	power W	Capacitor µF
	V	Hz		l/s	CFM	mm H ₂ o	inch H ₂ o						
661CHL016DC13	220	50	3	100,00	212,00	61,00	2,40	2850	68	0,70	3,40	150,00	
	380	50	3	100,00	212,00	61,00	2,40	2850	68	0,40	2,00	150,00	
	220	60	3	115,00	243,80	86,00	3,38	3250	71	0,80	3,45	225,00	
	380	60	3	115,00	243,80	86,00	3,38	3250	71	0,46	2,00	225,00	
	220	50	1	100,00	212,00	61,00	2,40	2850	68	0,75	3,10	155,00	10,00
	380	50	1	100,00	212,00	61,00	2,40	2850	68	0,45	1,80	155,00	3,20
	220	60	1	115,00	243,80	86,00	3,38	3250	71	1,10	2,85	240,00	10,00
	380	60	1	115,00	243,80	86,00	3,38	3250	71	0,65	1,70	240,00	3,20

DRAWING AND AIRFLOW CURVE

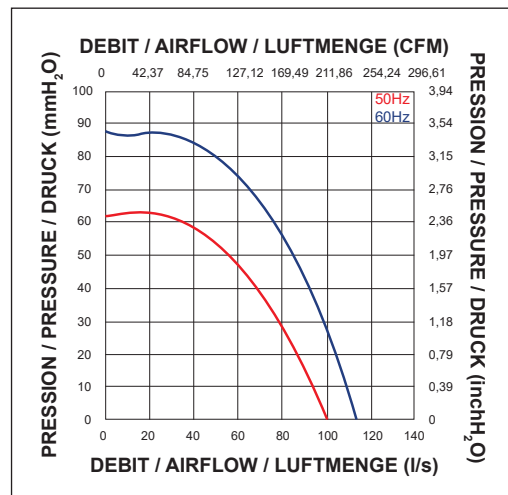
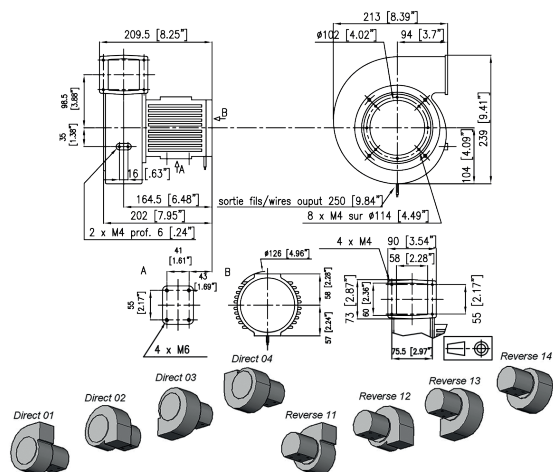

Non contractual document. All specifications are subject to change without prior notice. For professional use only. Please refer to the conditions of use of our catalogue.